

DRG No. POLV50TR54AX1- BB SERIES

COPYRIGHT RESERVED

ISSUE

REVISION

DATE

APPR'D

ROLLER DATA
 SPEEDS <70 M/MIN.
 ANTI-STATIC DESIGN
 PRECISION 6202 BRGS

UD Load rating in KG Force, based on BB (installation size in MM):-
 147KG <700BB | 85KG @ 800BB | 70KG @ 1000BB

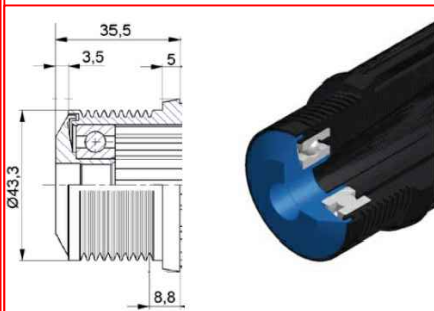
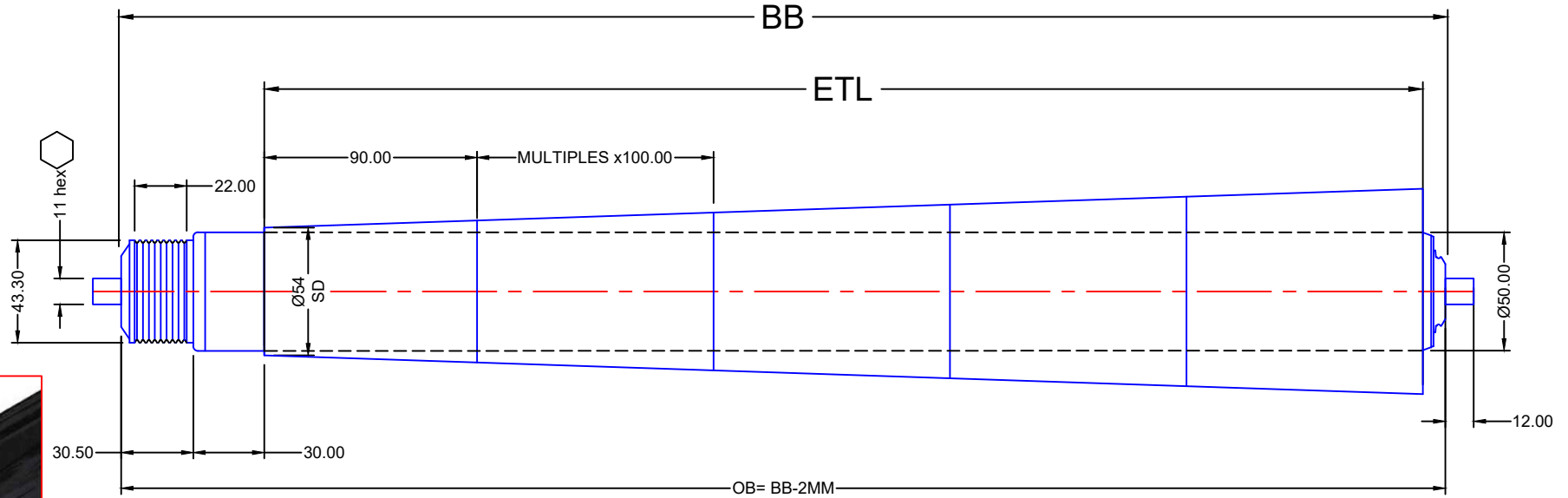
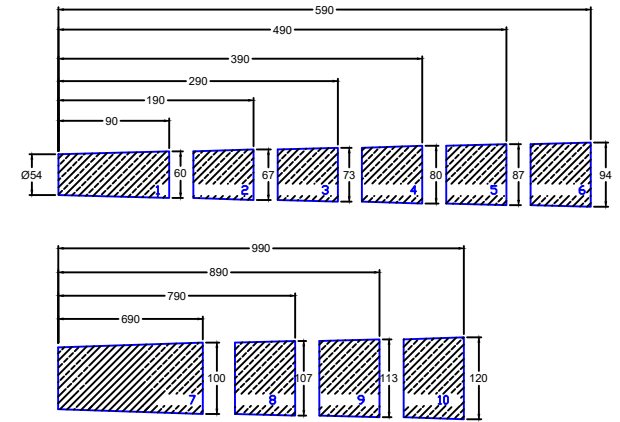

Replacing the six typical technologies used in the conveyor systems:
 flat belt, round belt, timing belt, twisted belt, tangential belt and chain

ORDERING CODE: POLYV50TR54AX1- BB

INSTALLATION LENGTH (BB)

FINISH	Z/PLATE
MATERIAL	MILD STEEL/ POLYMER
HEAT TREATMENT	AS PER BRGS SUPPLIED
LUBRICATION	AS PER BRG SUPPLIED

DRAWN: P. BEVAN

DATE: 29.6.18

TITLE: CORNER POLY VR BELT DRIVE SLAVE ROLL

DRG No. POLYV50TR54AX1- BB SERIES