

NSPR Series Extra duty & Belt Tension Roller

AX8 ENDS



Steel, heavy duty rollers, manufactured for:-

High speed Belt Conveyors | Belt Tension rolls | Heavy Industry | Air Cargo

Construction: Roller shell precision machined ends to accept deep groove bearings & through axle

Roller Type	Roller Diameter & wall thickness (CDS BS EN 10305-1 2002 E235+C)	Axle Diameter	Bearing Type (Deep Groove Precision)	Load Capacity* (UDL x>75%)
NSPR-32HD	Ø31.75 x 3	Ø10 & Ø12	6200 /6001 2rs	160 kgF udl <700 IF
NSPR-32HD5	Ø31.75 x 5	Ø12	6001 2rs	205 kgF udl <700 IF
NSPR-35HD	Ø35 x 3	Ø12	6001 2rs	272 kgF udl <700 IF
NSPR-38HD	Ø38.10 x 3	Ø15	6002 2rs	350 kgF udl <700 IF
NSPR-40HD5	Ø40 x 5	Ø12 Ø15 Ø17	6201, 6002, 6003 2rs	450 kgF udl <760 IF
NSPR-50HD	Ø50.80 x 3	Ø17 Ø20 Ø25	6204+IR20PP , 6005 2rs	450 kgF udl <880 IF
NSPR-50HD5	Ø50.80 x 5	Ø20 Ø25	6204+IR20PP , 6005 2rs	580 kgF udl <880 IF
NSPR-60HD5	Ø60 x 5	Ø20 Ø25 Ø30	6304, 6205 6006 2rs	700 kgF udl <990 IF
NSPR-63HD5	Ø63.50 x 5	Ø20 Ø25	6304, 6205 2rs	840 kgF udl <990 IF
NSPR-76HD9	Ø76.20 x 9	Ø25 Ø30	6305+IR25PP, 6206 2rs	2200 kgs udl <900 IF

IMPORTANT: *Load Capacity calculated using 20C Temperature, standard lengths (in MM) & axle fixing. Please ask to confirm advisable load on quotation/order. Uniformly Distributed Load (UDL) x >75% Installation Length (BB)

NSPR Series with female thread ends (D&T). Precision machined ends to accept quality bearings & fitted with though axle. Optional: Tube surface can be crowned for belt tracking. Chain sprockets maybe added to tube diameter

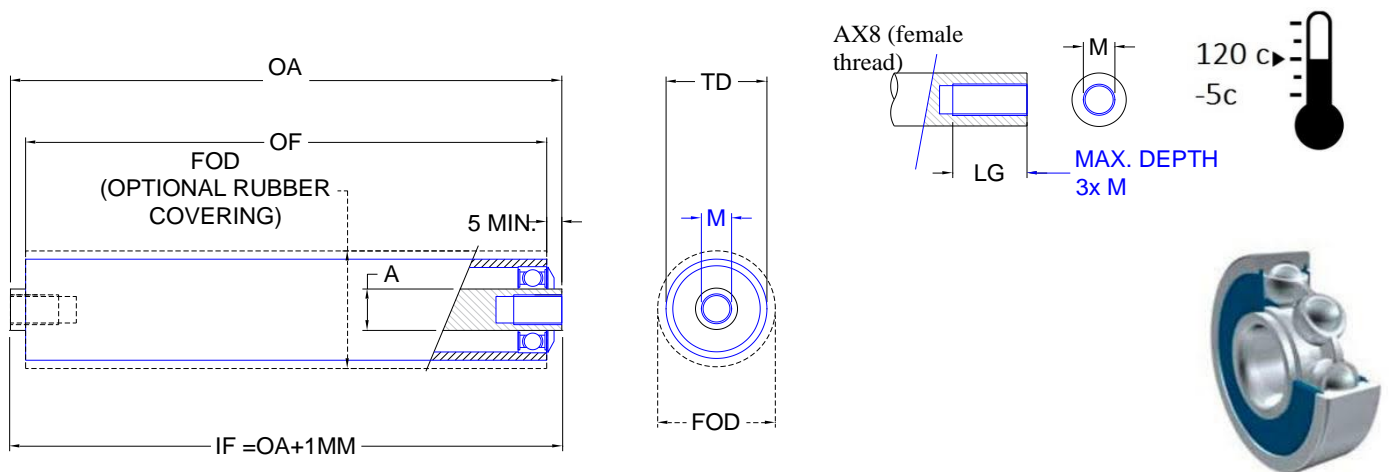

Quantity	Roller Type	OF Roller Length	OA Axle length	IF (Optional)	AXLE Ø A	FOD (Optional)	AX8 dimensions (ie M8x 16LG)
	NSPR				Ø		M x LG
	NSPR				Ø		M x LG
	NSPR				Ø		M x LG

NOTES:

Company Name and address:-

Signed.....Print.....

Date:

Purchase order No.:

Collect or Send by Carrier – circle as appropriate

Please sign & return Order